



DesignBoard
The Robust New Architectural Solution

DESIGNBOARD

A highly durable, 100% recyclable solution for wet areas, sanitary installations and outdoor products.

DesignBoard is a new range of sheet products for the savvy architect that requires a highly resilient and functional material, while simultaneously meeting the green objectives of their projects.



Designboard is a purposely created thermoplastic product designed with the longevity and the environment in front of mind. It features anti-graffiti and water resistant properties among others, which not only increases the lifetime of the project, but significantly decreases the maintenance. This is why DesignBoard is most often specified in those public spaces with heavy foot traffic and exposure to harsh elements over prolonged periods. Restrooms, wet environments and any outdoor applications are where you will find DesignBoard feels most at home.

Made with a 100% recyclable material, DesignBoard will not end up in landfill, instead being reborn into a new application. It is therefore ideally suited for the environmentally conscious architect or builder who understands the importance of recyclability and conservation. DesignBoard holds a *Verified Green* tag global specifier product rating.

DESIGNBOARD

DesignBoard is ideal for the following applications:

- Toilet and shower partitions
- Modesty screens
- Wet area lockers
- Wet area benches
- Change and locker room seating
- Counter tops
- Science laboratory bench tops

DESIGNBOARD UV

DesignBoard UV is a UV stabilised grade of the standard available product. It has all the benefits of the original, but can withstand the harshness of UV rays generated by the hot Australian sun.

DesignBoard UV is fantastic for the following applications:

- Outdoor furniture
- Outdoor cabinetry
- Outdoor sporting equipment and apparatus
- Outdoor aquatic centres
- External facades and feature walls
- Signage

Both grades of DesignBoard are 100% Recyclable, are approved under the Ecospecifier program and come with a limited 20 year warranty.



**20 YEAR
GUARANTEE**

KEY FEATURES OF DESIGNBOARD

+ **100% Recyclable**

Made from 100% recyclable materials, DesignBoard will meet your conservation needs.

+ **Moisture Resistant**

A special polymer that will not absorb moisture, so is ideal for wet areas.

+ **Graffiti Resistant**

Clean even the toughest paint and permanent marker graffiti off DesignBoard, rendering the product ideal for public restrooms, clubs and pubs.

+ **Resistant to Mildew, Mould & Odours**

The high quality material naturally does not allow the harbouring of any nasties within the material, and is guaranteed for 20 years.

+ **Impact Resistant**

A naturally tough material, decreasing the sheets exposure to impact damage.

+ **100% Colour Throughout**

The colour in DesignBoard is not just on the surface, allowing the aesthetic of the sheet's colour to show through, regardless of where you cut it. It also minimises the appearance of scratches.

+ **Chemically Inert**

This material is chemically inert so it will not readily react with other harsh chemicals, including cleaning agents and solvents.

+ **Will Not Break Splinter or Fade**

Unlike other available solutions, DesignBoard will not splinter at the joints or fade over time, greatly extending the lifetime of your application.

+ **Virtually Maintenance Free**

On top of the above features, DesignBoard has self-cleaning properties, rendering it virtually maintenance free.

+ **UV Resistant (DesignBoard UV Only)**

DesignBoard UV is also resistant to harsh UV rays.



DESIGNBOARD COLOUR RANGE



DESIGNBOARD UV COLOUR RANGE



PRIVACY REBATE OPTIONAL

Availability of a special privacy rebate in the sheet edges for use in partitioning applications. This allows for total privacy in the door cracks of cubicles.

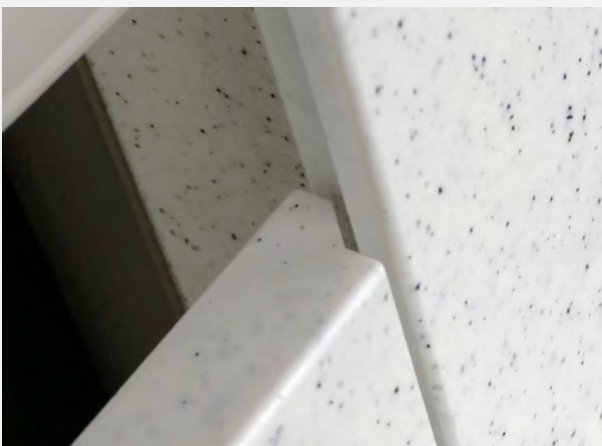

STANDARD SHEET SIZE

All colours in both DesignBoard and DesignBoard UV come in a standard sheet size of:

19mm Thickness, 2100mm(L) x 1800mm(W)

(NB: Available in 3600mm(L) x 1800mm(W) on project basis.)

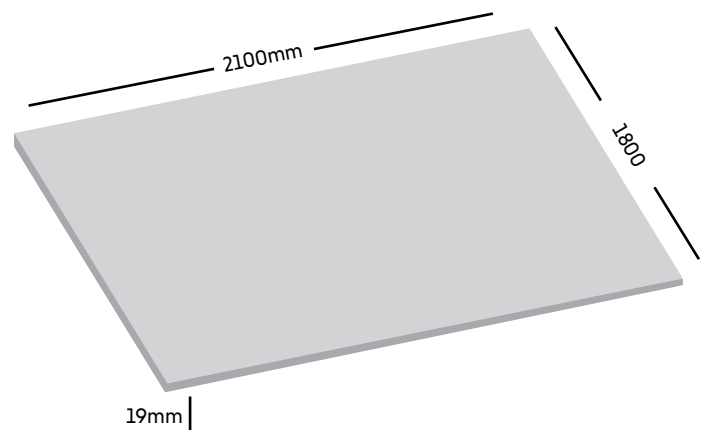

Date Updated: 21.03.2018

PROPERTY	TEST METHOD	UNIT	RESULT
GENERAL			
Specific Gravity	ASTM D792	-	0.96
ENVIRONMENTAL			
Water Absorption	ASTM D570	%	<0.01
Abrasion Resistance	Taber CS 17	mg/1000	-
Oxygen Index	D2863	%	-
Flammability	UL 94	-	N.R
Coefficient of Friction	ASTM C1894	Static/Dynamic)	0.2/0.2
MECHANICAL			
Tensile Strength @ yield	D1708, ASTM	MPa	24.8
Elongation @ break	D1708, ASTM	%	700
Flexural Modulus	ASTM D790 @23	MPa	1,206
Notched Izod Impact	ASTM D256 @23	N	13
Hardness, Shore D	ASTM D2240	-	68
THERMAL			
Continuous Service	Maximum	°C	76
Melting Point °C	ASTM D3418	°C	131
Vicat Softening Point	D1525	°C	124
Coefficient of Expansion	ASTM D696	mm/mm, °C x10-5	17
Heat Deflection Temp.	ASTM D648	°C	73
Heat Deflection Temp.	ASTM D648	°C	43
FDA			
FDA reg. 21 Chapter 1 part	FDA	-	Yes

DISCLAIMER: All specifications are deemed to be approximate values in respect of the specific material and may vary depending on the processing methods used. Suitability of materials for a specific field of application must be assessed by the party responsible for processing or the end-user. All technical specifications presented herein are designed merely to provide assistance in terms of project planning and are general guidelines only. They do not constitute a guarantee of specific properties or qualities. As such Plastral Pty Ltd makes no express or implied warranties regarding the materials. Any damages of whatsoever nature resulting from the improper use of these materials is strictly the responsibility of the buyer. Plastral Pty Ltd limits its liability to the replacement cost of any defective material. For further information, please contact our support team at info@plastral.com.au.

**Sydney****Head Office & DC**

130 Denison Street

Hillsdale NSW 2036

T: 02 9695 3200**E:** info@plastral.com.au**Melbourne****VIC Office & DC**

370 Darebin Road

Thornbury VIC 3071

T: 03 9490 0111**E:** info@plastral.com.au**Brisbane****QLD Office & DC**

U6/112 Cullen Ave West

Eagle Farm QLD 4009

T: 07 3623 2455**E:** info@plastral.com.au**Perth****WA Office & DC**

247 Camboon Road

Malaga WA 6090

T: 08 9248 6565**E:** info@plastral.com.au**Auckland****NZ Office**

Building 10

666 Great South Road

Penrose 1061

T: +64 9571 0636**E:** info@plastral.com.au

Your DesignBoard Partner

